

Installation Guidelines for Timber Roof Trusses



CONTENTS

SECTION 1	SCOPE AND GENERAL
1.1	GENERAL
1.2	APPLICATION
1.3	DOCUMENTATION
1.4	SERVICES
1.5	ANCILLARY TIMBER
1.6	TRANSPORT AND STORAGE
1.7	SAFETY
1.8	ROOF ANCHORS & GUARDRAILS
1.9	TRUSS MODIFICATIONS OR REPAIR
1.10	CONSTRUCTION LOADS
SECTION 2	SUPPORTING STRUCTURE
2.1	GENERAL
2.2	LOAD-BEARING WALLS
2.3	NON-LOAD-BEARING WALLS
SECTION 3	TRUSS INSTALLATION
3.1	GENERAL
3.2	SET OUT
3.3	LIFTING
3.4	FIRST TRUSS
3.5	SUBSEQUENT TRUSSES
3.6	ERECTION BRACING AND TOLERANCES
SECTION 4	ROOF BRACING
4.1	GENERAL
4.2	BATTENS
4.3	TOP CHORDS
4.4	BOTTOM CHORDS
4.5	WEBS
4.6	TOP HAT CONSTRUCTION
SECTION 5	TRUSS CONNECTIONS
5.1	HIP ENDS
5.2	GIRDER
5.3	GABLE-END TRUSSES
5.4	VALLEYS
5.5	OVERHANGS

SECTION 1 SCOPE AND GENERAL

1.1 GENERAL

Timber roof trusses are engineered and manufactured to an exacting standard which require special handling,

erection and bracing techniques. To ensure that the expected performance is achieved, it is imperative that all relevant parties are familiar with the requirements set out in this document.

The guidelines in this document are a sub-set of the full Australian Standard® AS4440-2004 “Installation of nailplated timber trusses”, and as such should be read in conjunction with this Standard.

Pryda Australia acknowledges Standards Australia for permission to reproduce some of the drawings and technical content from within AS4440-2004.

1.2 APPLICATION

This document intends to apply to nailplate timber roof trusses within the following general limitations:-

- Residential structures (NCC Building classes 1, 2, 3 and 10) and light commercial structures
- Maximum roof pitch 45 degrees
- Maximum truss span 16m
- Maximum design wind speed of 74m /sec

1.3 DOCUMENTATION

It is the builder’s responsibility to supply all of the relevant information required for the truss designs. It is recommended that the truss manufacturer confirms all details prior to manufacture.

1.3.1 Layout

A roof truss layout must be obtained prior to erection, with the following points considered:

- Check dimensions of the supporting structure prior to manufacture
- Check the truss layout to identify the trusses, and also check for the correct orientation of trusses – two span, multiple and cantilever trusses.
- Check that the supporting structure is adequate for the loads to be applied, especially where girder trusses are located, and lintels
- Check that information on roof bracing, bottom chord bracing (including the need for BC ties, if applicable) and any other applied loading (solar tank etc) on the roof is provided.
- Check that information on truss to truss connections, tie-downs, web-ties, scabs etc is provided clearly on the layout.

TYPICAL TRUSS LAYOUT AND TRUSS TYPES (Note: bracing not shown for clarity)

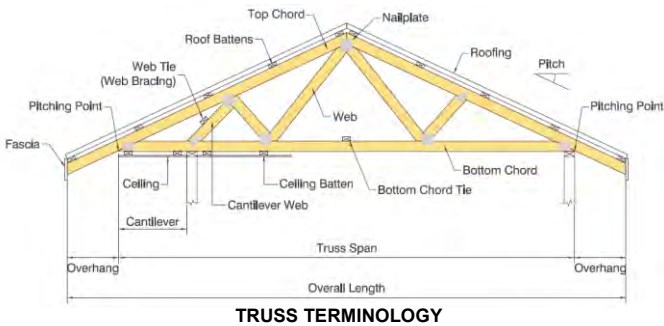
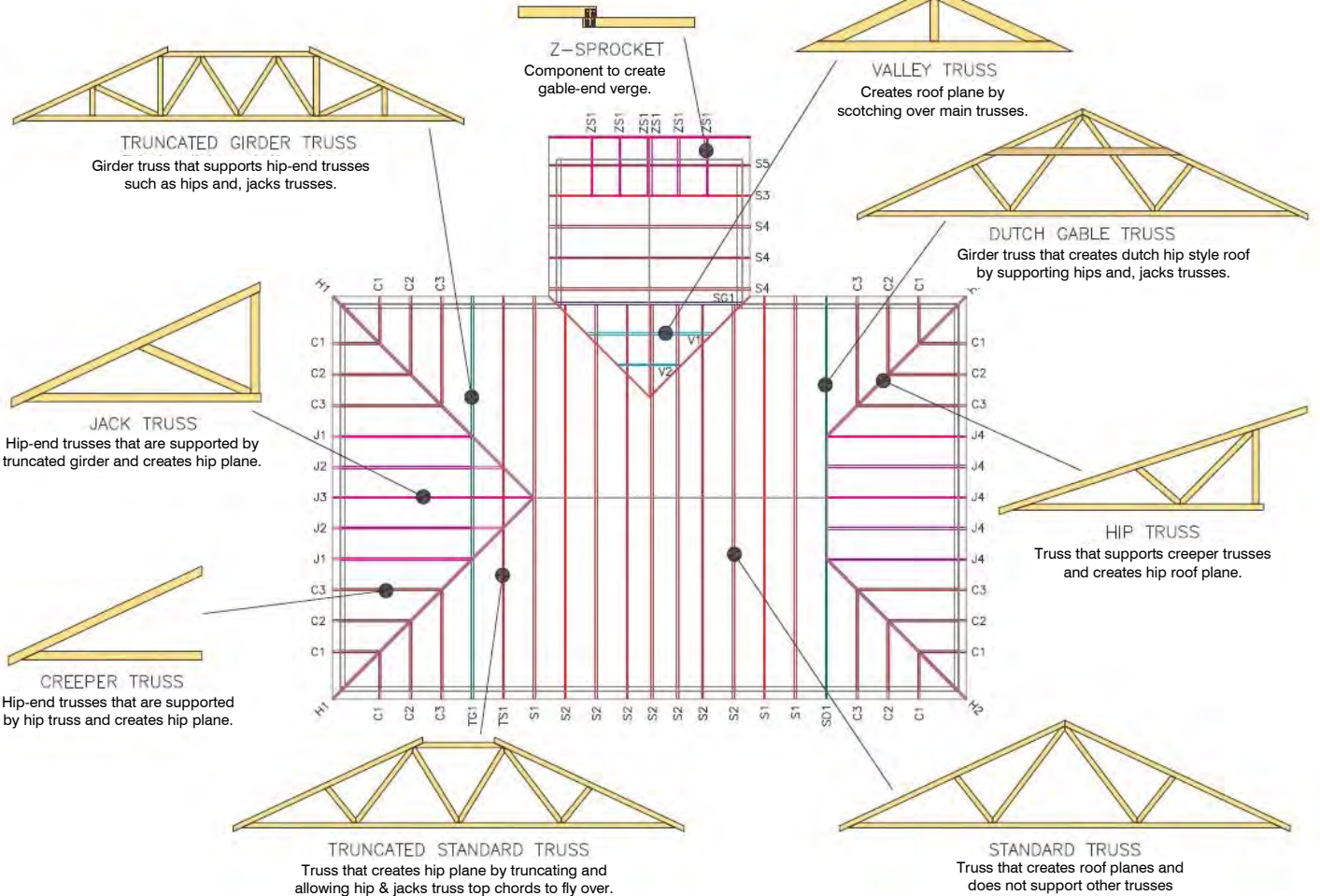

1.4.2 Hot Water Services

Hot water services are best supported directly on internal walls, but where this is not possible, and the trusses are required to carry this load, then the truss manufacturer must be consulted for special design

1.4.3 Solar Hot Water Services

For solar powered hot water services, with internally or externally mounted water storage tanks, refer to the truss manufacturer for appropriate details. If the solar tank or panels are installed on the roof, seek advice from truss manufacturer.

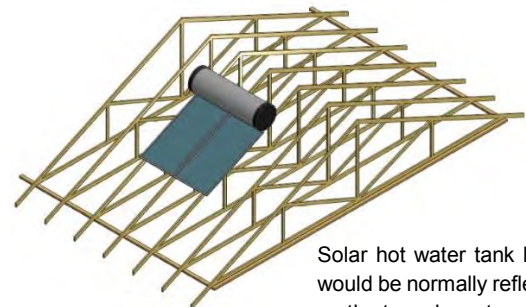

Solar hot water tank loads would be normally reflected on the truss layout.

1.4 SERVICES

1.4.1 General

Roof trusses are capable of supporting service loads from heating units, air-conditioned units, hot water service etc, provided the design takes them into account. The truss manufacturer must be consulted for advice.

If trusses require modification to accommodate these services, it is best practice to consult the truss manufacturer before any alterations are made to a truss.

Do not cut out any truss member without asking!

1.5 ANCILLARY TIMBER

Check that adequate ancillary timber is available where required (eg for temporary bracing).

1.6 TRANSPORT AND STORAGE

During transportation, in either the flat or upright positions, the trusses must be fully supported, taking care whilst tying down to avoid putting undue strain on the truss members. Trusses should be stored on the job site clear of the ground and kept flat to avoid distortion. All trusses should be inspected on delivery, and any damaged trusses reported to the truss manufacturer immediately to ensure correct rectification.

Trusses must be protected from weather, before and after installation. Prolonged exposure to rain and sun can be detrimental to both the timber (fungal damage, splitting, distortion etc) and nailplates (loss of embedment and corrosion).

If trusses are stored under tarpaulin or similar cover, adequate ventilation must be provided. This can be achieved by leaving the ends of the cover open to allow air to flow through freely and by spreading apart each stack of trusses. Free air circulation will help dry out any condensation that could accumulate under the cover.

It is best practice to install roof trusses within a week or two prior to installation of roof cladding.

1.7 SAFETY

The installation of timber roof trusses must adhere to the relevant safety work practices for the general construction of roofs. This will require that barriers or safety lines be installed at the appropriate time. These systems must not modify the trusses, not put loads onto the trusses, unless prior written approval is provided by the truss manufacturer.

Section 8.5 of the **Safe Work Australia publication, "Preventing Falls in Housing Construction – Code of Practice – July 2012"** provides good guidance on safe erection methods for roof trusses. It is recommended that the requirements in this Code of Practice are well understood by the installer prior to erecting trusses.

Under the heading **SAFE ERECTION METHODS FOR ROOF TRUSSES**, this Safe Work Australia publication provides strict guidelines for a person erecting trusses. It states that at no time is any person to stand on or work from an external wall top plate without suitable fall protection. Below is an extract from this publication:

The erection of trusses may be undertaken from internal wall top plates or from scaffold planks supported on internal wall top plates provided:

- no person works closer than 1.5 metres to an external wall, including gable end walls
- no person is exposed to the risk of a fall into a stairwell or other void
- planks are adequately supported across their spans.

The allowable spans for timber planks are given in Table 1 of section 2.2 Appendix B of "Preventing Falls in Housing Construction – Code of Practice – July 2012".

Laminated timber, aluminium and steel planks must be used in accordance with the manufacturer's directions.

When trusses are erected at up to 600 mm centres, persons working between the trusses to fix or brace them can use the erected trusses as a form of fall protection under controlled conditions as described below. If trusses are erected at greater than 600 mm centres, refer to Section 8.5 of this Code of Practice for suggested methods of working safely at heights.

Truss bottom chords are considered a safe working area for a competent person if all the conditions below are met.

If the person erecting trusses is to walk or work from the bottom chords of the trusses, you should ensure that:

- trusses are adequately braced to stabilise the structure. If the bottom chord is used to support the person erecting trusses, then it should be laterally restrained by ties at a maximum 3000mm centres (refer Section 3.6.2 for more details)
- only a competent person works at heights
- suitable footwear that provides good foothold is worn
- a nominated competent person from the truss erection team oversees the work
- a competent person or the truss manufacturer/supplier has provided the necessary detail and instructions, including advice in regard to installers standing on the bottom chord
- the bottom chord is visually checked by a nominated competent person for defects that may compromise the material's structural integrity (i.e. knots, splits, cracks and rotting timber) before walking on it.

1.8 ROOF ANCHORS & GUARDRAILS

Roof trusses are not normally designed to resist loading from roof anchors or guardrails. Seek advice from the truss manufacturer. Safety anchor requirements (type and location) should be determined and given to the truss manufacturer before the detailed design of trusses occurs.

Read Pryda Technical Update TU26 for further information on upgrading trusses to receive guardrail posts.

1.9 TRUSS MODIFICATIONS OR REPAIR

Trusses must not be modified on site without the prior written approval from the truss manufacturer.

The installer must report any damage, alterations or installation errors to the truss manufacturer immediately and must not attempt to repair a truss without a rectification detail from the truss manufacturer.

It must be noted that trusses and the type of damage could vary immensely, and each repair should be treated on its merits. The truss installer must refrain from using his prior knowledge or any 'standard' detail that he might have.

1.10 CONSTRUCTION LOADS

Extreme caution must be demonstrated when placing construction loads on roof trusses. Stack only reasonable amount of materials, by ensuring they are located along external supports or directly over internal supports of a properly braced structure. Construction materials must not be placed at locations that will produce instability such as ends of cantilevers or girder to girder connections, and should not be dropped on trusses.

Failure to heed these recommendations could result in bodily injury and/or property damage.

SECTION 2 SUPPORTING STRUCTURE

2.1 GENERAL

To ensure a satisfactory roof line on completion, the supporting structure must be plumb, and the load bearing top plates are level across the building. This will ensure support heights are maintained level, and consequently a level ceiling line is achieved.

Care must be taken to ensure that the supporting structure (walls, beams etc) is adequately designed and stable in its own right.

All trusses are to be fixed to the supporting structure with appropriate fixings, typically Pryda Multigrips, etc. The selection of the fixing depends on the magnitude of the support reaction (uplift) and the nature of the support. Refer to Section 5 for details.

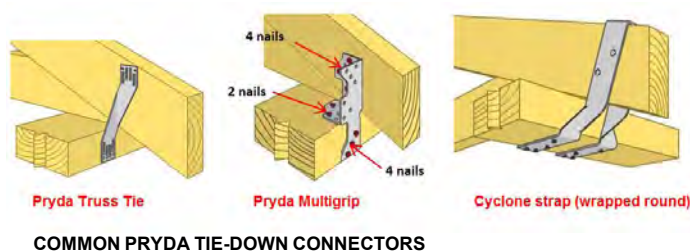

2.2 LOAD-BEARING WALLS

This is where the full load from the roof trusses is supported on walls - generally the exterior perimeter walls, but may occasionally also include some internal walls (eg: multiple span trusses)

Internal Support Walls - If internal walls are required as supports, the truss itself and the layout shall be marked accordingly, and this intention must be made very clear. The installer shall ensure that trusses are orientated correctly when using internal walls as supports. The supporting structure, including footings, should be checked by the builder to allow for this load.

Note: If the trusses were inadvertently provided a camber at the internal support locations, it is necessary to pack under the truss BC to ensure full bearing, prior to loading.

Refer to **AS1684 -2010** "Residential Timber-framed Construction" for the wall plate, stud and lintel installation details.

Heavy, concentrated loads such as from girders and truncated girders are best supported directly over studs, with special attention given to the load path all the way down the structure to the foundations.

2.2.1 Lintels and Support Beams

Lintels and support beams must be correctly sized and supported in order to limit deflection, and to ensure a level bearing surface is provided for the roof trusses in the long term.

2.3 NON-LOAD-BEARING WALLS

Non-load-bearing walls shall not carry any truss loading at any time, and shall not be packed to touch the underside of the truss. It is common to set non-load-bearing walls lower than the supporting walls by an amount equal to the depth of the ceiling battens plus 10mm. The truss is still required to stabilize the top of the wall, and this is done by using Pryda Partition Hitches which are nailed near the top of the vertical slots. Do not embed the nail heads fully home, as the truss must be allowed to settle downwards as time passes and the camber comes out of the truss.

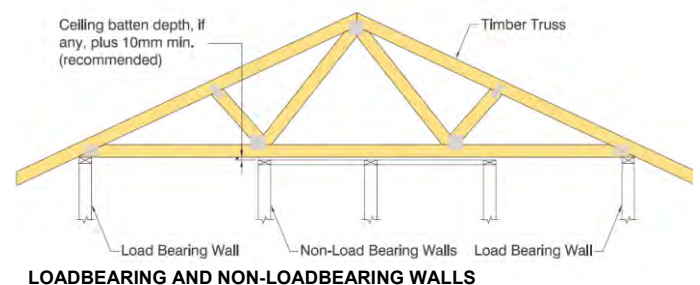

2.3.1 Fixing top plates to truss bottom chords of non-loadbearing walls

a) Bracing wall

Pryda Shear Connectors are used to transfer racking loads from truss bottom chords to the bracing walls.

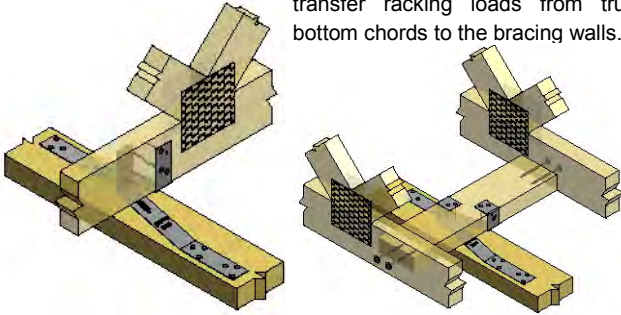

b) Non-bracing wall

Pryda Hitch Brackets are used to stabilize the top of non-load bearing internal walls, required at 1800mm c/c. They are fixed to the truss bottom chords through slotted holes which allow vertical movement of trusses.

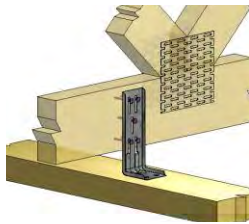

- Points to check**
- Nail near top of slot
 - Don't drive nail home
 - Allow trusses to deflect
 - Fixed at not more than 1800mm c/c

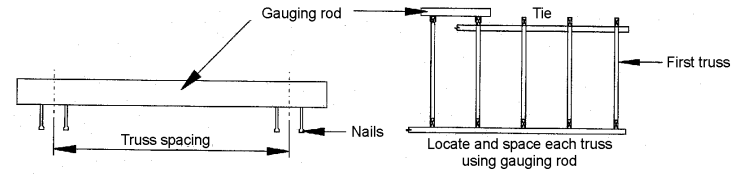

3.3 LIFTING

Trusses must always be lifted in a manner that minimises lateral bending stresses. It is preferable that they be kept strapped in bundles until they are erected, as this reduces the chances of damage.

Trusses may be lifted either by crane, or manually. The choice will depend on the truss weight and wall height. They should be maintained in a vertical plane as much as possible when being handled individually.

Trusses lifted by crane require slings or spreader bars as shown in the diagrams. Where trusses are placed in bundles directly onto the top plate, it is imperative that they are supported by internal walls and that the supporting structure is stable in its own right.

SECTION 3 TRUSS INSTALLATION

3.1 GENERAL

The following recommendations are guidelines only, as the details are the responsibility of the roof truss installers. Refer to AS4440-2004 for greater detail.

3.2 SET OUT

Prior to lifting any truss into place, it is often convenient to mark out the truss locations on the top plate, using the supplied truss layout for reference.

Girder and truncated girder trusses should be set out first as they have specific, fixed locations. Dual purpose trusses such as truncated girder / girders need special attention as they may appear similar to other trusses which must not be used accidentally instead.

Standard trusses must then be set out, taking care not to exceed the design spacing. Generally they would be evenly set out over runs of similar trusses. But it is also acceptable to space them at the design spacing and have a closing gap smaller than this - adjacent to a more heavily loaded truss, if possible.

A gauging rod is very useful for setting out trusses. Pryda Truss Spacers may also be used for this purpose.

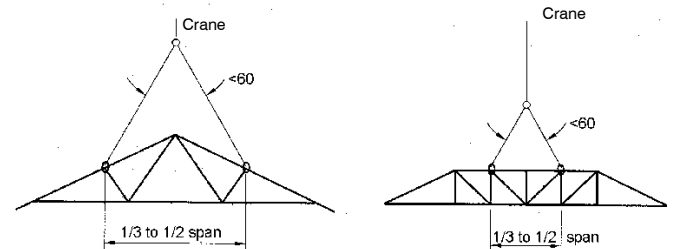

VERTICAL LIFTING OF TRUSSES – SPAN LESS THAN 9m

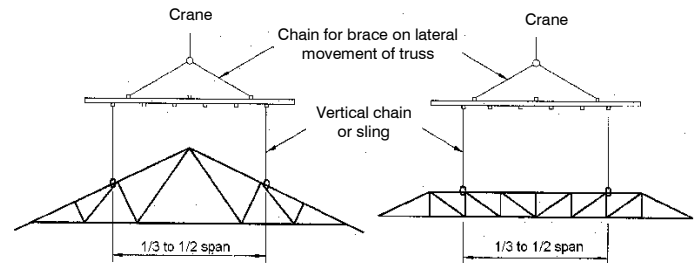

VERTICAL LIFTING OF TRUSSES – SPAN FROM 9m TO 16m

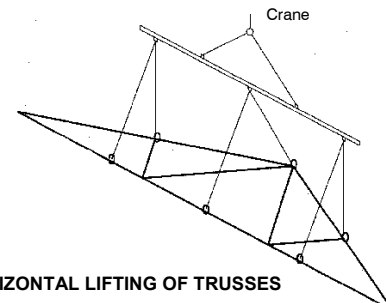

HORIZONTAL LIFTING OF TRUSSES

When erected manually, they may be slid flat over the side walls on skids spread at 3m intervals, then rotated

vertically into position – supported at the apex and panel points to ensure that they do not distort or sag between supports during this process.

When positioning multiple span or cantilever trusses, take care that they are the correct way around. Such trusses will have markings on the bottom chord showing the point of internal support.

Also refer to Section 8.5 of the Safe Work Australia publication, “Preventing Falls in Housing Construction – Code of Practice – July 2012” for safety aspects when lifting trusses

3.4 FIRST TRUSS

3.4.1 Gable roofs

On gable roofs, start with the gable truss which is located over or just inside the end wall. Then brace it back to the ground, or to some other stable part of the structure.

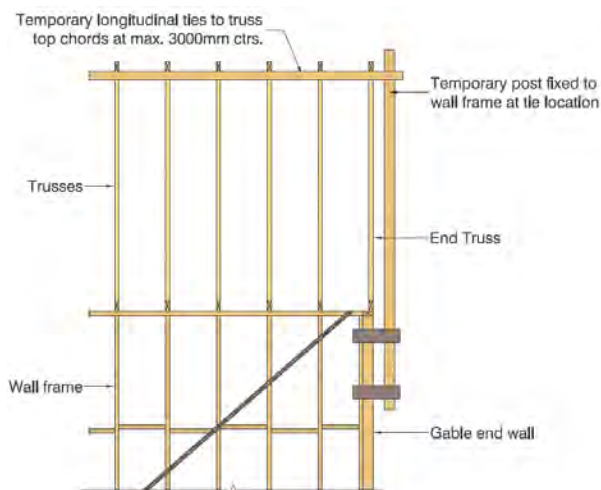

**TEMPORARY BRACING FOR GABLE END ROOF
METHOD 1 – POST WALL FRAME**

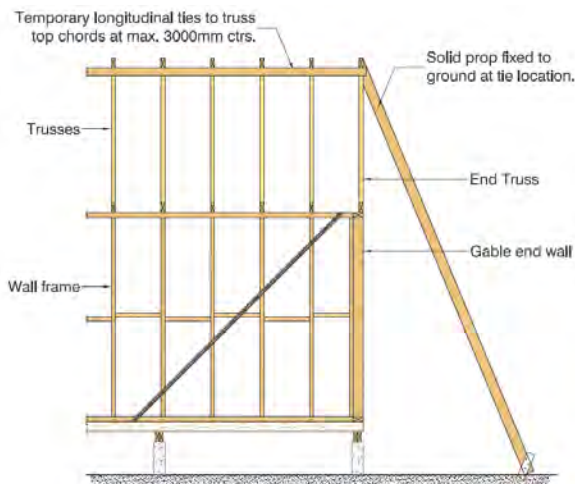

**TEMPORARY BRACING FOR GABLE END ROOF
METHOD 2 – PROP TO GROUND**

Some gable end trusses are designed to sit on the end wall. In these cases, it must be supported at every bottom chord panel point along its length, as it cannot act as a clear span truss.

3.4.2 Hip and Dutch gable roofs

On hip and Dutch gable roofs, start with the truncated girder, apex girder or Dutch hip girder truss and brace it back to the corner of the building as shown. It is important that this truss be correctly plumbed and aligned, as other trusses must fit exactly up against it.

Where it is not feasible to install bracing of the first truss in the manner described, the first two or three trusses can be erected and cross-braced between them to form a stable unit.

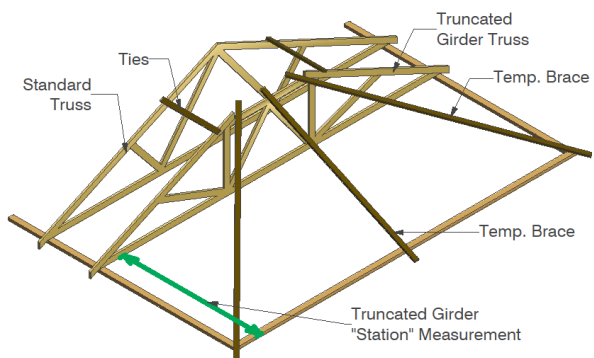

TEMPORARY BRACING FOR HIP OR DUTCH-HIP END ROOF

3.5 SUBSEQUENT TRUSSES

As each truss is installed, fix it to the top plate at the required location, usually indicated by set-out marks, or by using a set-out rule. Use a gauging rod and ties for spacing the trusses, and a string line along the apex to ensure correct alignment.

It is important that trusses are lined up along the apex, not the heels.

Any multi-ply truss must be fixed together prior to being installed. If the truss manufacturer has not done this at the factory, it is his responsibility to supply the fixing information, and the erecting crew's responsibility to ensure that this fixing is properly carried out.

3.6 ERECTION BRACING AND TOLERANCES

As the trusses are erected, they must be braced longitudinally. This is to provide stability to the trusses during the erection process, and the bottom chord ties should be maintained in place after full installation is completed.

However, the temporary top chord ties may be removed once the roof battens are adequately fixed in place.

Refer to AS 4440-2004 for the full details for temporary bracing, however the following is a brief summary.

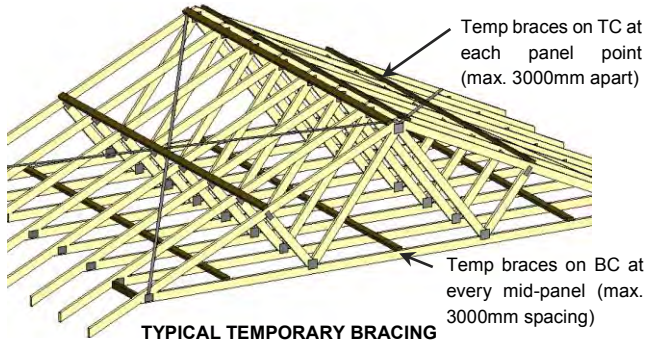

3.6.1 Top chords

Temporary braces at each top chord panel point. (maximum 3000 mm apart).

50 x 25 F5 or MGP10 for heavy roofs (eg: tiled)

70x35 F5 or MGP10 for light roofs (eg: sheet steel)

3.6.2 Bottom chords

Temporary braces at all mid-panels (maximum 3000mm apart), but not required for creepers, jacks, hip trusses, Dutch hip girders and TG trusses with stations up to 3600mm. Use 70 x 35 F5 or better, fixed with 2/65 nails or 1/65 screw per truss crossing.

Where the bottom chord is not laterally restrained by the ceiling, or by battens, ie exposed trusses or suspended ceiling, then the truss designer's requirements must be strictly followed.

3.6.3 Tolerances

Trusses shall be installed straight and vertical and in their correct positions.

Bow – trusses shall be installed with bow not exceeding the smaller of span/200 nor 50mm.

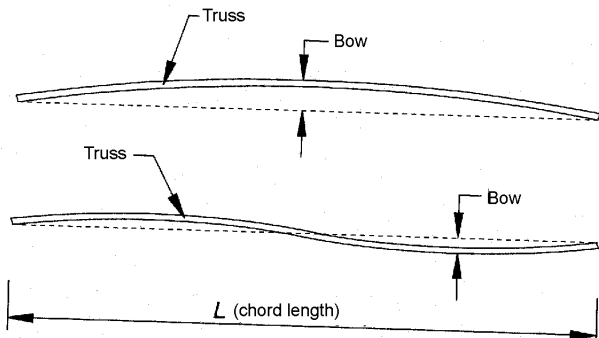

Plumb – trusses shall be installed so that no part of the truss is out of plumb by more than the smaller or height/50 or 50mm.

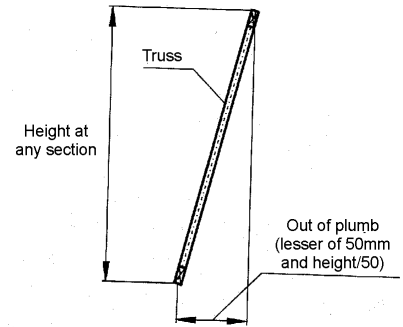

These tolerances will produce a good roof line, and the performance of the trusses will deteriorate rapidly if these are exceeded, producing excess deflections and overstress in the truss.

SECTION 4 ROOF BRACING

4.1 GENERAL

The following recommendations allow for bracing of the roof system only and assume that the walls are stable in their own right.

Bracing to the trusses is essential to prevent buckling of members (chords and some webs), and to provide overall stability to the roof under all relevant loading conditions, including wind uplift where members may reverse from being in tension to being in compression.

Care should be taken to ensure that all supporting structure bracing is in place prior to the trusses being installed.

4.2 BATTENS

The bracing of top chords is achieved via the overlying battens or purlins. Battens are to be nailed to both outer laminates of any multiple ply trusses eg. double girders.

Splice locations are restricted:-

- Not more than one third of the battens should be spliced at a single truss, and there must not be two splices adjacent to each other at any truss.
- Areas in the vicinity of the ends of gable roofs, should be as free of splices as practical.
- Splices are not permitted at girder trusses unless approved by the truss manufacturer in writing. This restriction does not apply to truncated girder trusses, nor to girder trusses that are designed to have roof plane bracing independent of the battens.
- Battens fixed to multi-ply girder trusses must be nailed into each outer ply forming the girder truss assembly.

Note: For battens in sheet roofs, provide special splice details as recommended by Pryda (refer Technical Update TU12)

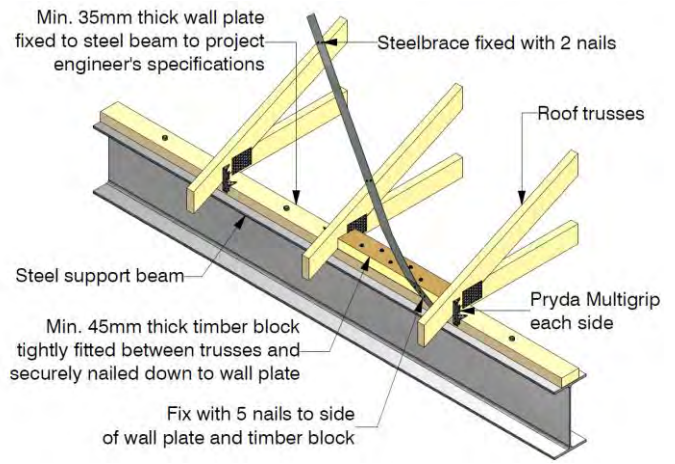
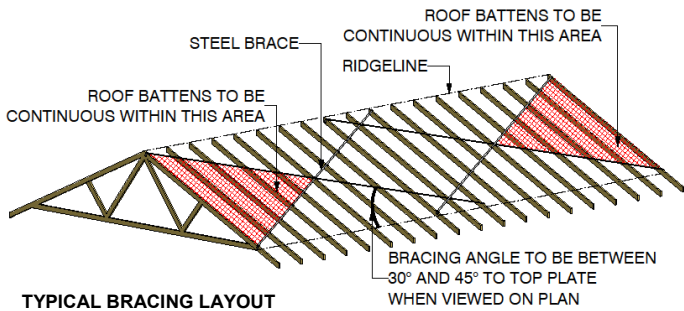

4.3 TOP CHORDS

All trussed roofs require diagonal bracing to the top chords, which is typically at an angle of 30-45 degrees to the ridge line, measured on plan. Braces should be installed such that each main truss has a brace on it.

Bracing is best located near the ends of buildings, and will be installed on both sides of the ridge line. Some typical examples are shown here, but full details are given in AS4440-2004.

4.3.1 SpeedBrace

The bracing shown here is Pryda Speedbrace which has been specifically designed for this purpose and should be fixed with 35x3.15 Pryda Timber Connector nails.

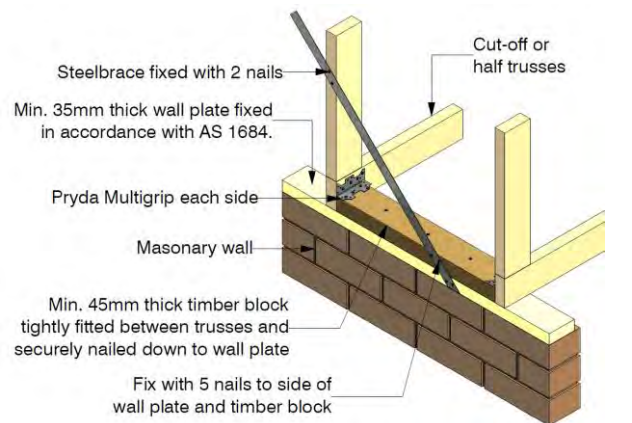
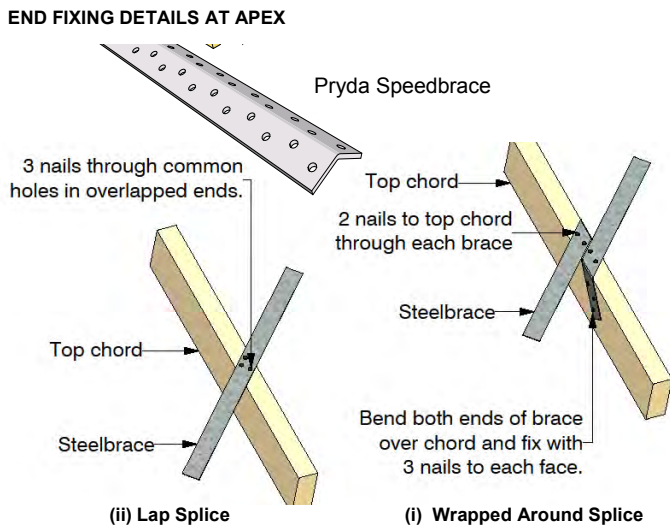
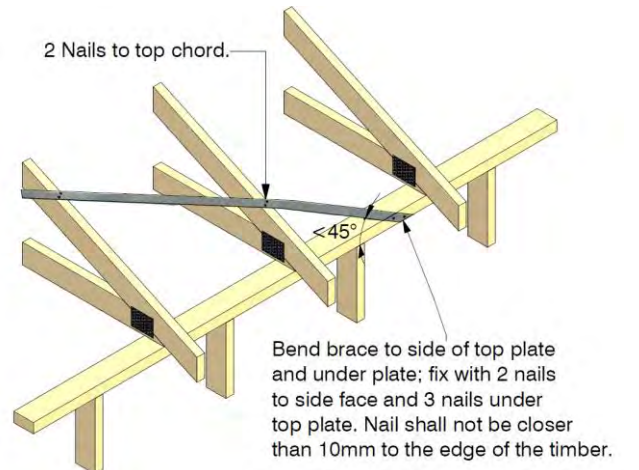
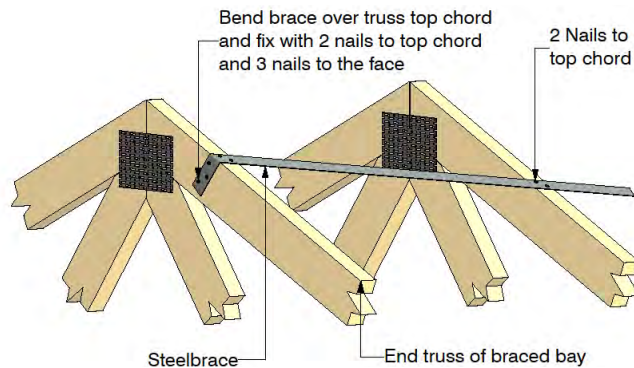
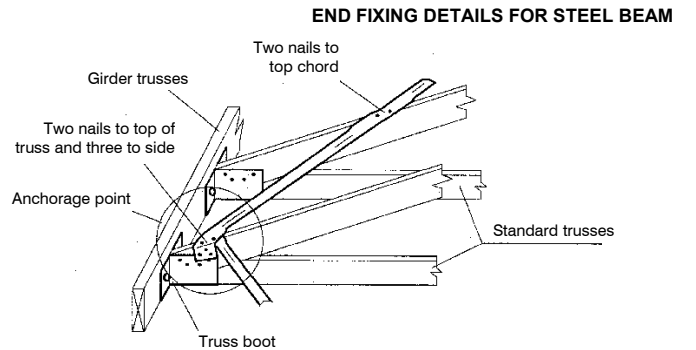

4.3.2 Cantilevers

It is essential that the force in the top chord bracing be transferred to the supporting structure. In cantilever trusses, this is achieved through the use of special details as shown in the diagrams.

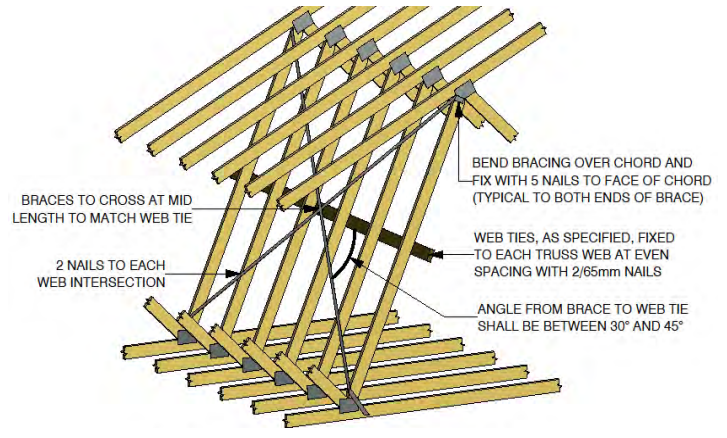
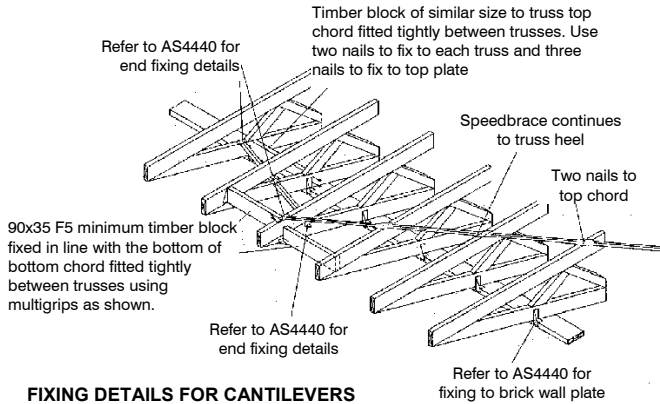

In addition to web ties, Pryda Web Stiffener, Tee-Stiffeners or scabs may be also designed to brace webs

4.4 BOTTOM CHORDS

Generally ceiling battens or ceiling fixed directly to the underside of the bottom chords is sufficient to provide lateral restraint against buckling.

Bottom chord ties, when used as lateral restraints, should be fixed adequately to the supporting structure and braced.

- For trusses over 12m span, or trusses where there is no ceiling, additional bottom chord bracing will be required.
- Additional bottom chord bracing or a wind truss may also be required where the ceiling diaphragm is considered to be incapable of transferring racking loads to braced walls.
- Additional bottom chord ties and bracing are required when ceiling is connected through metal furring channels that are only clipped onto the bottom chord. The truss layout should indicate details of this.

In each of these cases, the requirement must be checked by an experienced truss designer, and the details supplied by the truss manufacturer.

4.5 WEBS

4.5.1 Long webs

Some webs must be braced if required by the truss designer. Generally this applies to long webs which are in compression during some part of the life of the structure. Typically this is a 70x35 F5 or MGP10 web tie located mid-length of the web. By itself it does nothing, so these web ties must be cross-braced back to part of the structure that can provide adequate resistance.

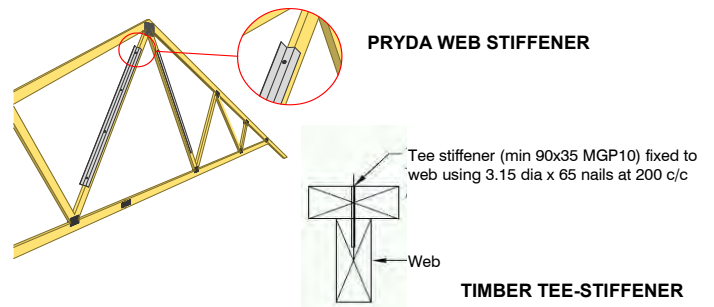

4.5.2 End webs

All trusses with end vertical webs not intersecting with another truss, will need end web bracing similar to the top chord bracing. Diagonal bracing from the top chord to the supporting structure should be provided at each end of each run of trusses as shown.

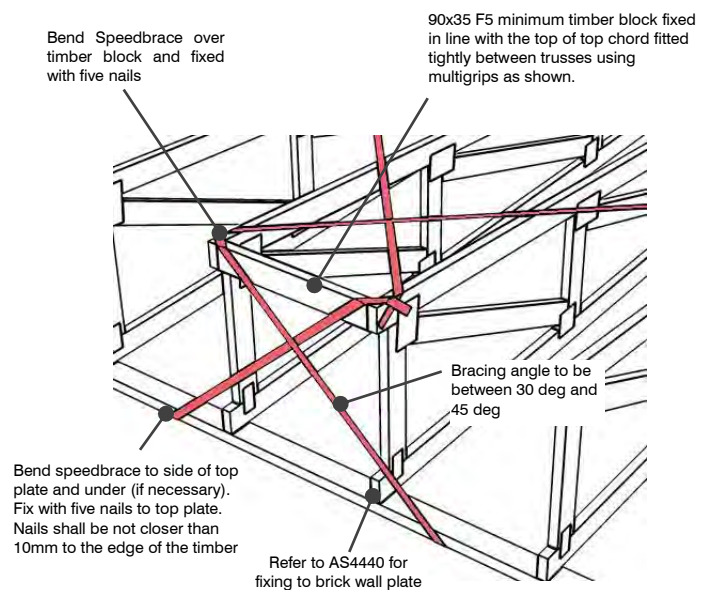

Timber blocks fixed in line with the chords fitted tightly between trusses.

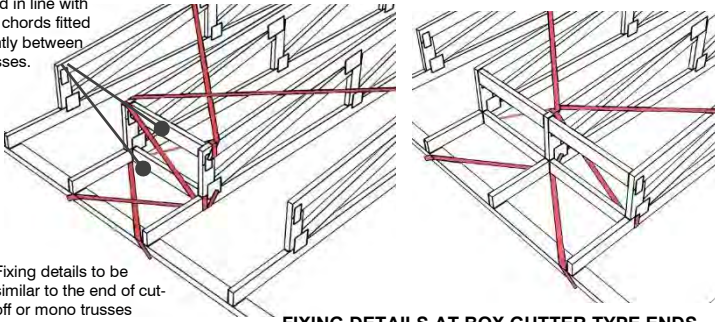

Fixing details to be similar to the end of cut-off or mono trusses

FIXING DETAILS AT BOX GUTTER TYPE ENDS

4.6 Top Hat Construction

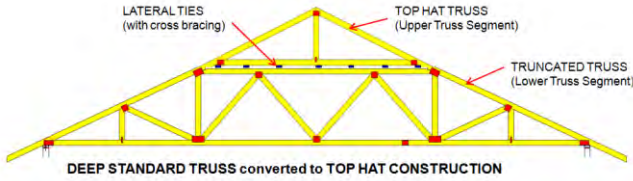

Truss manufacturers may choose to form a truss in two segments, Top Hat Construction, often dictated by manufacturing or transportation restrictions. This form of construction requires special consideration, especially bracing and lateral restraints for horizontal top chord of the lower truss. Obtain further details from your truss manufacturer.

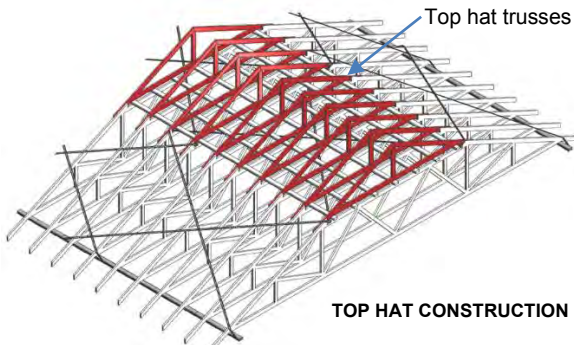

SECTION 5 TRUSS CONNECTIONS

5.1 HIP ENDS

The details shown here are for a maximum design wind of 50 m/sec (non-cyclonic). Refer to AS 4440-2004 for full details including up to 74 m/sec cyclonic.

The hip end connections provided by Pryda Build software are similar to those in AS4440-2004, but they may not be exactly the same, as every connection is designed specifically for the conditions at each site.

The requirements called up by Pryda Build take precedence over AS4440 or any other guideline. A document (Software Update No. 7) is available to produce to certifiers if required.

Description	Connection Details
<p>Hip truss to truncated trusses</p> <p>Top chord – one Pryda multigrip bent to suit, with 3.15 x 35mm Pryda Connector nails into the side of each top chord for truncated girder</p> <p>Bottom chord – three effective flat-head 65mm nails.</p>	<p>Detail A1</p>
<p>Jack truss to truncated girder truss</p> <p>Top chord – one Pryda multigrip bent to suit, with 3.15 x 35mm Pryda Connector nails into the side of each top chord for truncated girder</p> <p>Bottom chord – three effective flat-head 65mm nails each side of jack truss.</p>	<p>Detail B1</p>
<p>Extended jack truss top chord to truncated standard trusses</p> <p>Two 65mm skew nails into the side of each top chord.</p>	<p>Detail C1</p>
<p>Creepers truss to hip truss (maximum jack station 1800mm)</p> <p>Top chord – three effective flat-head 65mm nails through jack truss top chord into hip truss top chord.</p> <p>Bottom chord – three effective flat-head 65mm nails through jack truss bottom chord into hip truss bottom chord.</p>	<p>Detail D1</p>
<p>Creepers truss to hip truss (maximum jack station 3000mm)</p> <p>Top chord – three effective flat-head 65mm nails through jack truss top chord into hip truss top chord PLUS one mitre plate with 3.15 x 35mm Pryda Connector nails to each chord</p> <p>Bottom chord – three effective flat-head 65mm nails through jack truss bottom chord into hip truss bottom chord.</p>	<p>Detail E1</p>

CONNECTION DETAILS – HIP-END TRUSSES FOR WIND CLASSIFICATION N1, N2, N3 OR C1
(Refer AS4440 for details in N4, C2 or C3)

5.2 GIRDERS

Where a girder truss is utilised to support the standard trusses perpendicular to it, they must be connected to the girder with special devices which:-

- Support the loads
- Prevent separation of the girder bottom chord away from the standard trusses
- Prevent rotational force being applied to the standard truss.

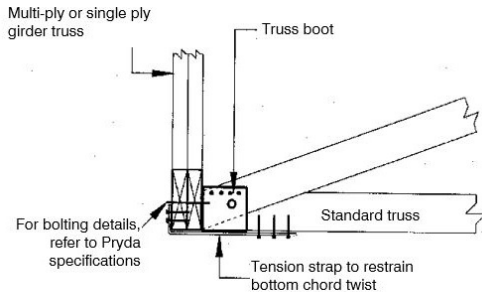

STANDARD TRUSS BOOT AND ANTI-TWIST BAR

5.2.1 Main girders

Standard trusses may be fixed to the girder truss by Pryda products. The truss manufacturer will generally supply the appropriate bracket for each connection, or otherwise specify.

It is important to fix the truss boot properly, i.e including fixing to incoming trusses, prior to roof being loaded. Otherwise bottom chord rotation can occur.

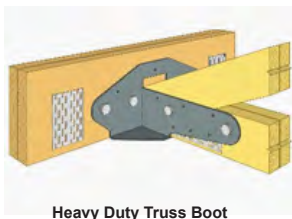

Heavy Duty Truss Boot

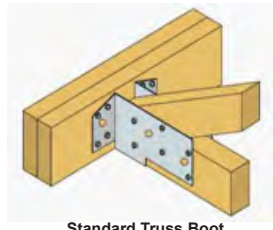

Standard Truss Boot

5.2.2 Dutch Hip Girders

The waling plate must be fixed to the Dutch Hip girder truss in accordance with the details supplied by the truss manufacturer.

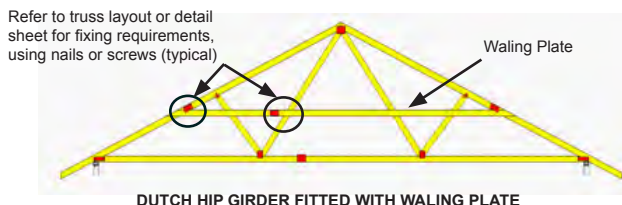

DUTCH HIP GIRDER FITTED WITH WALING PLATE

5.3 GABLE-END TRUSSES

Special care shall be taken to ensure face wind loads from end wall are not applied directly on the gable-end truss. Refer to Pryda's publication on Gable-end Framing for further details.

5.4 VALLEYS

Where overlying members sit on the top chord of a truss, the nominated top chord restraint must still be maintained. This can be achieved with careful detailing as shown here.

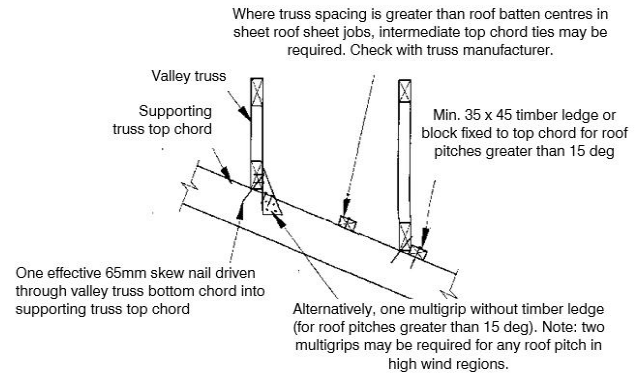

FIXING DETAILS FOR VALLEY TRUSSES

5.5 OVERHANGS

It is important that overhangs are supported as intended by the truss designer. Refer to AS4440-2004 for full details.

5.5.1 Strutted Overhangs (Boxed Eaves)

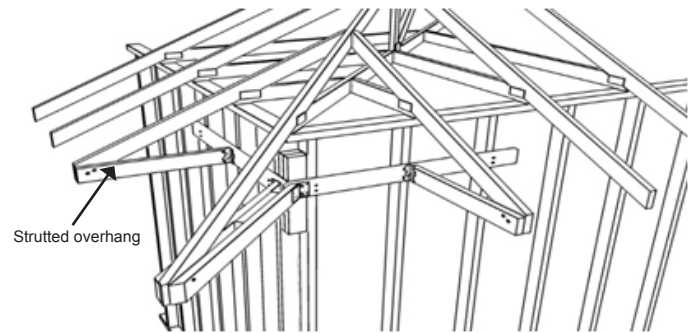

Strutted overhang

Struts at hip corners and other areas must be fixed in accordance with the details supplied by the truss manufacturer.

5.5.2 Verge Overhangs

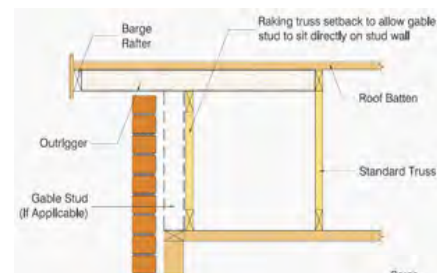

OUTRIGGERS

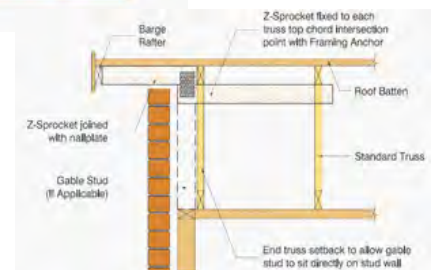

ZED SPROCKETS